

REMEMBER THE OTHER TERMINAL

The recently updated General Aviation terminal handles an average of more than 100 flights per day and serves a special class of traveler. Reach these elite visitors with targeted advertising designed to greet them upon arrival.



GENERAL AVIATION BACKLIT DISPLAYS

Located in the general aviation terminal, these 24 x 24-inch backlit displays will catch the eyes of non-commercial travelers.

General Aviation Backlit Display \$75/month

AIRPORT DISPLAY LOCATION GUIDE

- (A) Ticket Counters
- (B) Airline/Travel Offices
- (C) Baggage Claim Carousels
- (D) Rental Car Counters
- (E) Information
- (F) Airport Police
- (G) Meditation Room
- (H) Terminal Services
- (I) Meeting Rooms
- (J) Administrative Offices
- (K) Security Screening
- (L) Meeter/Greeter Area
- (F&B) Food and Beverage
- (R/N) Retail/News
- (R) Restrooms

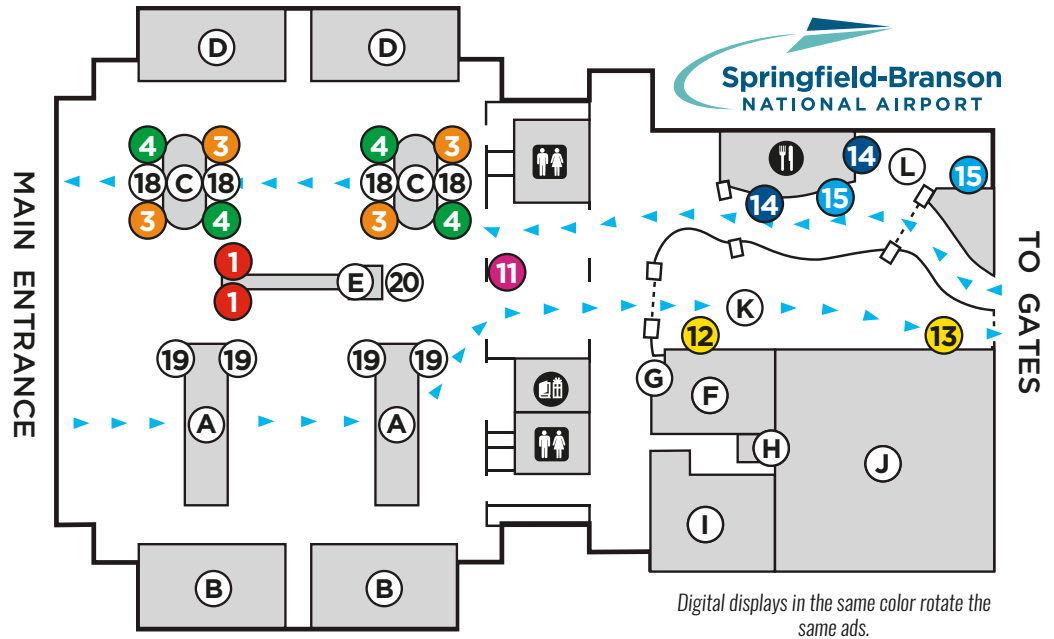

Contact one of our Partner Development Managers for assistance in developing a marketing program tailored for your business.



Convention & Visitors Bureau

Offices and Route 66 Springfield Visitor Center:

815 East Saint Louis Street • Springfield, Missouri 65806

417-881-5300 • 800-678-8767

Airport Visitor Center:

Springfield-Branson National Airport • Springfield, Missouri

SPRINGFIELDMO.ORG

TRUE TO LIFE. TRUE TO US.

**TOURISM BRINGS PEOPLE TO SPRINGFIELD.
THEY COME FOR BUSINESS, FAMILY AND FUN.
THEY COME TO PLAY, MEET, EAT AND STAY.
VISITORS MEAN BUSINESS!**



Convention & Visitors Bureau

Airport Marketing Opportunities

THE POWER OF PARTNERING

When you partner with the Springfield Convention & Visitors Bureau you stretch your advertising dollars and get access to unbeatable advertising packages that allow you to reach potential customers across Springfield and around the world. All airport advertising options include these benefits at no additional cost:

Website Listings – Receive a free listing on the CVB website (SpringfieldMo.org) and the Springfield-Branson National Airport website (FlySpringfield.com).

Brochure Distribution – The CVB will reserve a space for your brochure to be prominently displayed at the Route 66 Springfield Visitor Center and the Visitor Information Center at the Springfield-Branson National Airport.

Contact one of our Partner Development Managers for a plan tailored for your business.

800-678-8767, Ext. 105

THE AIRPORT BRINGS VISITORS

More than 1.5 million potential customers pass through the airport each year. These people have purchasing power! Specially targeted advertising will help direct them to your business or event.

CONCIERGE TOUCH DISPLAYS 1

These interactive touch displays are in the airport lobby at the end of the fountain. The package includes a single banner graphic that rotates on both displays. Your business name will be displayed on a button that will give information about your business. Customers can phone your business by pressing the “call” button and using the connected phone.

Concierge Digital Touch Display Package (2 displays) \$150/month



BAGGAGE CAROUSEL DIGITAL DISPLAYS 3 OR 4

These attention-grabbing, rotating ads face new arrivals waiting for their luggage. Price includes 1 full-screen graphic or video that plays on 4 displays for 10 seconds before rotating to another ad. A maximum of 6 ads and 1 public service message will show on 4 matched displays, ensuring that your ad will be seen at least once every minute.

Baggage Carousel Digital Display (4 displays) \$500/month

WELCOME AREA DIGITAL SIGN 11

This eye-catching digital sign is in the sitting area between the lobby and the gates. It shows full-screen and split-screen advertisements that rotate between a maximum of 6 advertisers on the full and 3 on the split screens.

Full-Screen Digital Ad \$150/month
Split-Screen Digital Ad (Zone 1) \$100/month
Split-Screen Digital Ad (Zone 2 or 3) \$75/month





MEETER/GREETER DIGITAL DISPLAYS 14 OR 15

Put an attention-grabbing ad where friends and family wait to meet arriving visitors. Price includes 1 full-screen graphic or video that plays for 10 seconds and rotates with no more than 6 total ads and 1 public service message on 2 of the 4 displays.

Full-Screen Digital Ad (2 displays) \$200/month

TERMINAL BANNER SIGNS

These big banners are sure to demand attention. There are two options available, each suited to your company's needs. The 3 x 10-foot vertical banners line the wall in the main terminal and allow for viewing while passengers wait on their bags. Double-sided 24 x 72-inch banners are mounted perpendicular to the wall along the hallway.

Vertical Lobby Banner \$500/month
Hallway Banner \$250/month



WALL MOUNTED BANNERS FOR SPECIAL EVENTS

Place your event ad for everyone to see! These large banners are placed above the hallway leading to the security checkpoint. Everyone passes through there and will not be able to miss your ad.

Wall Mounted Banner call for details

TICKET COUNTER POSTER DISPLAYS 19

Put a BIG ad right by the ticket counter. These 67 x 67-inch printed static displays are mounted on each side at the end of the 2 ticket counters where they are sure to be seen by those in line.

Ticket Counter Poster Display \$200/month



LOBBY LIGHTWALL DISPLAY PACKAGES 20

Located right beside the Visitor Information Center at the Springfield-Branson National Airport and in the lobby of the Springfield Exposition Center, these 24 x 18-inch panels are a great way to sell your business.

3 displays (2 at Airport and 1 at Expo Center) \$2,400/year

COBRA FREE-STANDING DISPLAYS

A unique, attention-getting way to display your ad! These nearly 6-foot-tall displays are placed in the location of your choice within the terminal building (subject to airport approval).

Cobra Free-Standing Display \$300/month

